

## Pump Model CPS 300-250-600

Speed 1450rpm

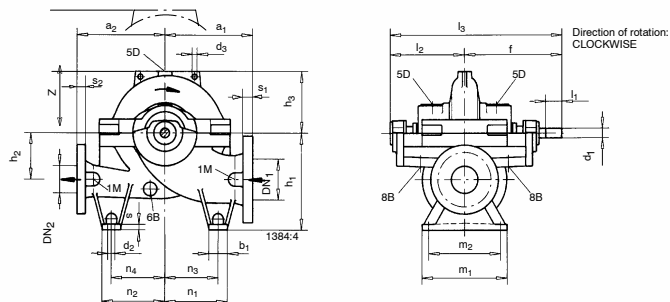
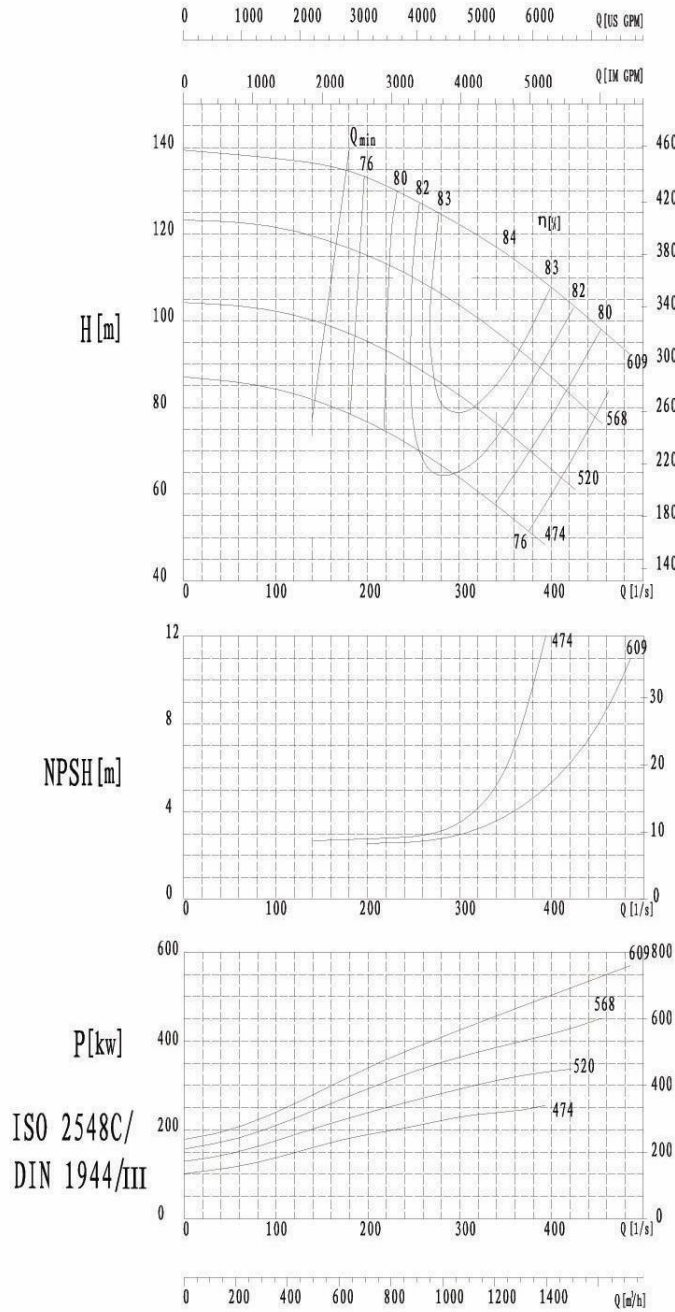

Pump Size	FLANGE DIMENSIONS				PUMP DIMENSIONS									
	DN1	DN2	s1	s2	a1	a2	d3	f	h1	h2	h3	l2	l3	z
CPS 300-250-600	300	250	50.8	47.6	650	550	12.5	730	630	350	415	515	1245	830
	FOOT DIMENSIONS					SHAFT					PUMP WEIGHT			
	b1	d2	m1	m2	n1	n2	n3	n4	s	d1	L1	(kg)		
	100	22	600	520	400	400	350	350	26	75	160	1215		